

NEW

Try to Dry

ANEST IWATA

Air cooled

Scroll Vacuum Pump

G V S A-500
General Vacuum Scroll Asia

New Vacuum Solution!

Anest Iwata, pioneer of dry scroll pump, has developed general usage dry scroll vacuum pump!

Air flush standard available for vapor operation (Optional)

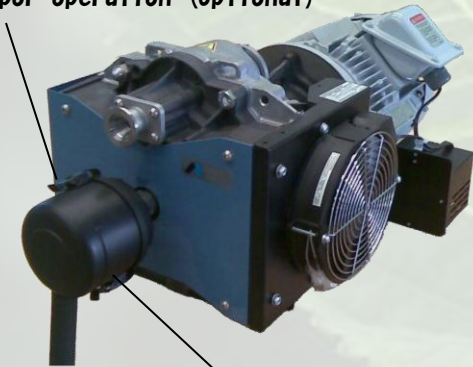

Water separator (optional)

High Ultimate pressure
Low Noise
Long Term Maintenance

Dry scroll

Applications

Vacuum Chuck

Vacuum Drying

Vacuum Transport

Vacuum Packing

Vacuum Forming

Gas Substitution

Deaerator

Leak Test

Model	Oil-free Scroll Vacuum Pump
Product	GVSA-500
Displacement	423 L/min(50Hz)
Ultimate pressure	≤250 Pa
Noise level	64 dB(A)
Motor power	1.5 kW
Voltage	3Phase AC380V(50Hz)
Connection	Inlet (Rc3/4) Outlet(Rc1/2)
Ambient temperature	5~40°C(in house)
Weight	39 kg
Dimension	W 317mm D 590mm H 304mm
Material of back up seal	Silicon rubber
Option	Water separator / Air Flush Back up seal : Fluoro rubber

High vacuum

Ultimate pressure 250Pa. Keep good vacuum level for Long term operation.

Low noise

Orbiting movement makes soft noise. Available near work shop.

Long life

Only annual maintenace interval for Standard usage. 24 hours operation available!

Maintenance

After sales service network for all major market is available and one of our quality.

Air cooled

No need to change oil or cooling water because of air cooling system!



ANEST IWATA SOUTHEAST ASIA Co.,Ltd.

91/1, 5AthFloor, Chaiyo Building, Rama IX Rd
Huaykwang, Huaykwang, Bangkok, Thailand 10320
Phone +66-(0)2-643-2870-3
Fax +66-(0)2-643-2874

※Models,specification and photos are subject to change without notice

Dimension

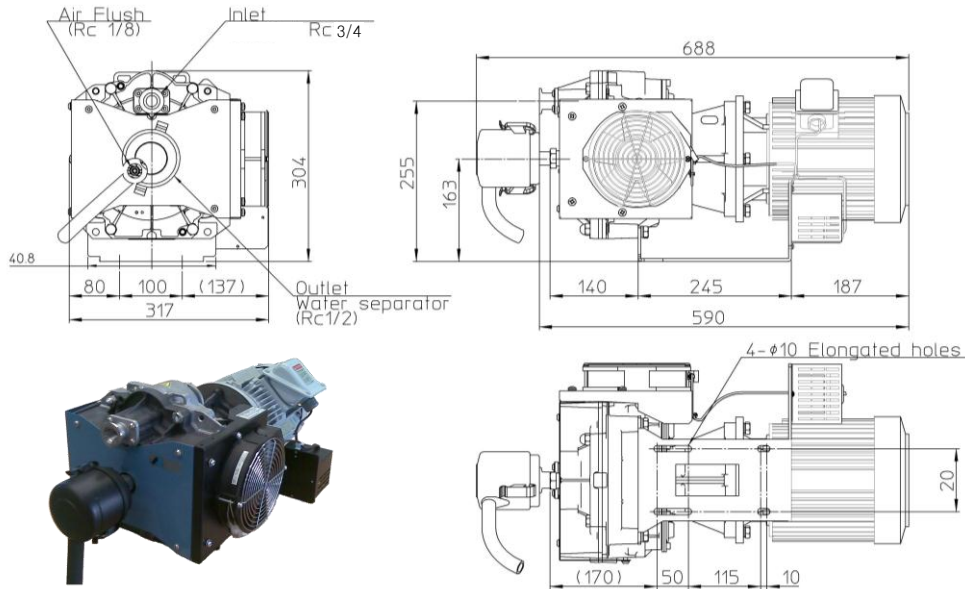

Applications

- Ⓞ Vacuum Chuck
- Ⓞ Vacuum Transport
- Ⓞ Vacuum Forming
- Ⓞ Gas Substitution
- Ⓞ Degassing
- Ⓞ Vacuum Drying
- Ⓞ Vacuum Packing
- Ⓞ Leak Test

Pumping Speed

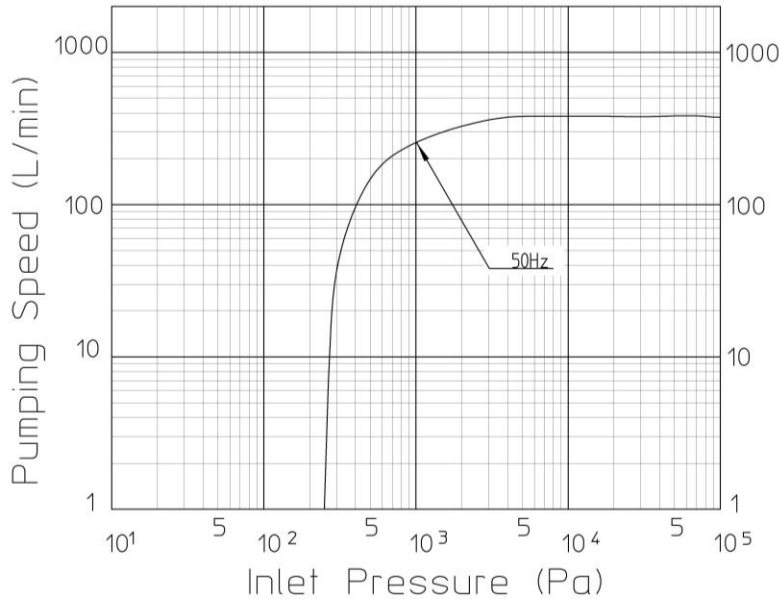

Option

- Ⓞ Control Box
- Ⓞ Hour Meter
- Ⓞ Filter



Precaution on Usage

- This vacuum pump is suitable for **clean processes only**.
- Do not use explosive, flammable, toxic or corrosive substances or substances which contain chemicals, solvents or particles.
- ANEST IWATA will not perform maintenance work on pumps which have used hazardous substances.
- Use at ambient operation temperature in the range of **5°C to 30°C**.
- Do not disassemble, reassemble or alter pump and parts on user's side.
- Be sure to read instruction manual and understand it fully before use.
- When maintenance interval has been reached, be sure to contact our distributor who sold it to you.
- The guarantee period is based on instruction manual. Maintenance interval and the guarantee period are different.
- Please contact at ANEST IWATA Corporation before exporting pumps which are shown on this catalog to out side of Japan.

Caution for installation

- Danger of explosion and fire.
- Install in an area which is not exposed to explosives, flammable gas, or other related things.
- Pumps which are shown in this catalog do not have breaker for avoiding motor burnout by installing. Avoid motor burnout using breaker.
- Electric source cord is not included in the pump.
- Use electric source cord which is instructed by instruction manual.
- This vacuum pump is required maintenance by interval which is shown on the instruction manual.
- Install the pump where it has enough ventilation and available maintenance.